

4 x \varnothing 10 PRZEZ WSZYSTKO

Notes:

1. Flange and shaft dimensions according to:
 - IEC standard,
 - customer request
2. Electrical parameters according to:
 - customer request
3. Optional equipment:
 - gear, encoder, DC brake,
 - DC controller (only with 12V, 24V, 48V versions).

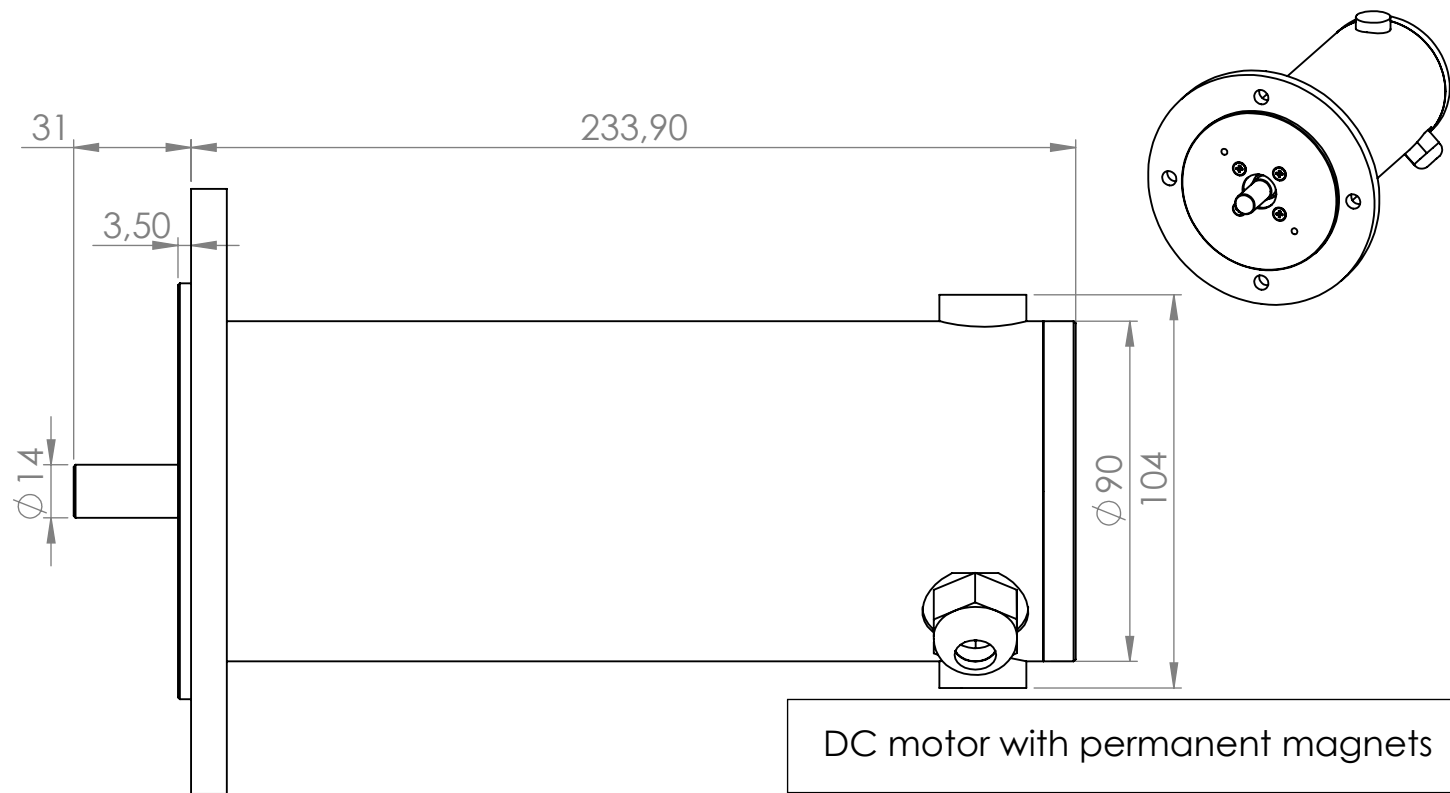

DC motor with permanent magnets	
Type	PRMO 91-120
No.	292
Power [W]	300
Duty	S1
Voltage [V]	70
Speed [rpm]	3000
Current [A]	4,9
IP	44
Weight	6